

End Cover surface electrophoresis (black)  
Except customer mounting surface

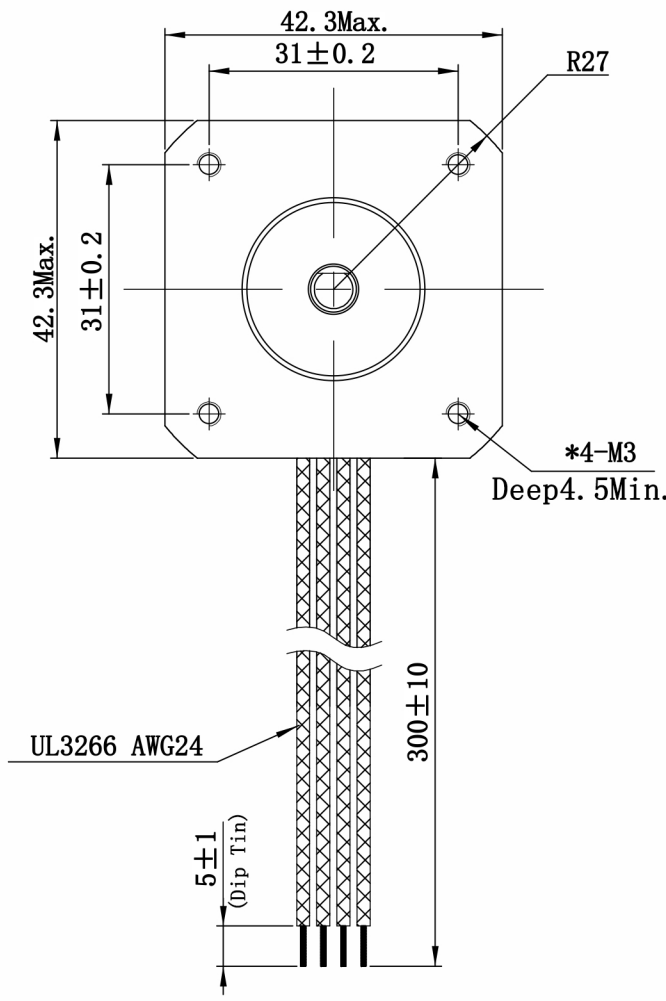

| Motor characteristic        |                      |
|-----------------------------|----------------------|
| Projects                    | Specifications       |
| Rated voltage               | 2 VDC                |
| Rated current               | 2.0 Amp              |
| Pitch Angle                 | 1.8° ±0.09°          |
| Phase number                | 2                    |
| DC cold resistance (25 ° C) | 1 ±0.1 Ω             |
| Winding inductance          | 1.9 ±20% mH          |
| Maximum Holding Torque      | 520 mN.m Typ.        |
| Insulation Resistance       | ≥ 100 MΩ (DC500V)    |
| Insulation Grade            | Class B              |
| Moment of inertia           | 76 g.cm <sup>2</sup> |
| Mass.                       | 0.36 kg REF.         |

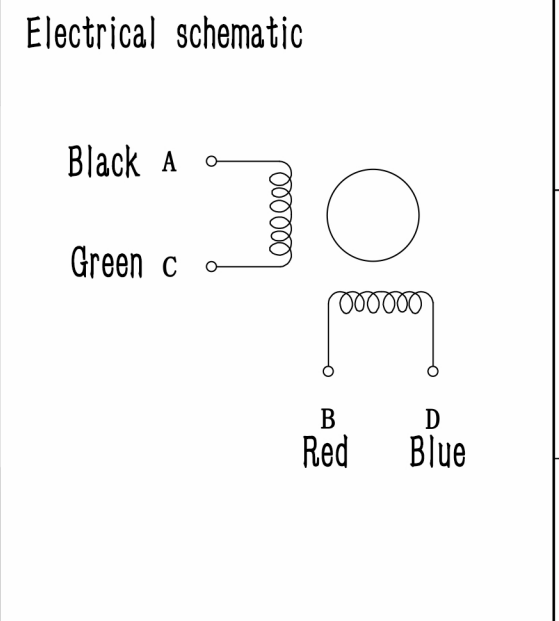

|         |                  |   |                |  |  |                 |      |  |            |
|---------|------------------|---|----------------|--|--|-----------------|------|--|------------|
|         |                  | The dimensions specified in the drawing shall prevail |                | Comparison table for undimensioned tolerance |  |                 |      | <br>Shenzhen Ruiqiang Technology co. LTD |            |
|         |                  | Unit:mm   | Proportion:1:1 | 0°   |  | 0               | ±0.2 |  |            |
|         |                  | Item number:  |                | 0.0°   |  | 0.0             | ±0.1 | Title                                    |            |
|         |                  | Motor Model: RQ42HS48-2004A                           |                | 0.00°  |  | 0.00            |      | Contour drawing                          |            |
|         |                  |   |                |  |  | Design/date     |      |  |            |
|         |                  |   |                |  |  | Audit/date      |      |  |            |
|         |                  |   |                |  |  | Approval/date   |      |  |            |
| A       | Initial release. | 2021.06.05  |                |  |  | Drawing number: |      | Page 1, total 1 page                     | Version: A |
| Version | Change content   | Date of issue   |                |  |  |                 |      |  |            |